

# Long-Reach Optical Access Networks: A Survey of Research Challenges, Demonstrations, and Bandwidth Assignment Mechanisms

Huan Song, Byoung-Whi Kim, and Biswanath Mukherjee

**Abstract**—Long-Reach optical access is a promising proposal for future access networks. This technology can enable broadband access for a large number of customers in the access/metro area, while decreasing capital and operational expenditures for the network operator. First, the paper reviews the evolutionary path of access networks and shows the drivers from technology and business perspectives for high bandwidth and low cost. A variety of research challenges in this field is reviewed, from optical components in the physical layer to the control and management issues in the upper layers. We discuss the requisites for optical sources, optical amplifiers, and optical receivers when used in networks with high transmission rate (10 Gbps) and large power attenuation (due to large split, transmission over 100 km and beyond, and propagation), and the key topological structures that allow to guarantee physical protection (tree-and-branch, ring-and-spur). Then, some relevant demonstrations of Long-Reach Optical Access Networks developed worldwide by different research institutes are presented. Finally, Dynamic Bandwidth Allocation (DBA) algorithms that allow to mitigate the effect of the increased control-plane delay in an extended-reach network are investigated.

**Index Terms**—Access Network, Long-Reach PON, demonstration, dynamic bandwidth allocation, optical amplifier.

## I. INTRODUCTION

MUCH of the R&D emphasis in recent years has been on developing high-capacity backbone networks. Backbone network operators currently provide high-capacity OC-192 (10 Gbps) links, with 40 Gbps transmission also quite mature now [1]. However, note that the telecom network hierarchy consists of the backbone network as well as the metro and access networks [1, 2]. Today's access network technologies such as Digital Subscriber Line (DSL) typically provide 1.5 Mbps of downstream bandwidth and 128 kbps of upstream bandwidth. While economies of scale have successfully enabled backbone networks to grow rapidly, the cost of access technologies remains prohibitively high for the average household [3]. The access network is the bottleneck for providing broadband services such as video-on-demand, interactive games, and video conferencing to end users.

In addition, DSL has a limitation that any of its subscribers must be within 18,000 feet from the Central Office (CO)

because of signal distortions. Typically, DSL providers do not offer services to customer more than 12,000 feet away. Therefore, only an estimated 60% of the residential subscriber base in the US can use DSL even if they were willing to pay for it. Although variations of DSL such as very-high-bit-rate DSL (VDSL), which can support up to 50 Mbps of downstream bandwidth, are gradually emerging, these technologies have even more severe distance limitations. For example, the maximum distance that VDSL can be supported over is limited to 1,500 feet. Some other variants of DSL include G.SHDSL (offering 2.3 Mbps in both directions), ADSL2 (offering 12 Mbps downstream), and ADSL2+ (offering 25 Mbps downstream).

Another alternative for broadband access is through Cable Television (CATV). CATV networks provide Internet services by dedicating some Radio Frequency (RF) channels in coaxial cable for data. However, CATV networks are mainly built for delivering broadcast services, so they don't fit well for distributing access bandwidth. At high load, the network's performance is usually low and cannot satisfy end users' expectations.

Moreover, it is expected that emerging applications such as Internet Protocol TV (IPTV), video-on-demand (VoD), video file swapping, peer-to-peer applications, real-time network games, etc. will demand much more bandwidth, and some of these applications may require symmetric bandwidth as well (equal and high bandwidth in both downstream and upstream directions) [4, 5]. Both DSL and CATV provide limited and asymmetric bandwidth access (lesser bandwidth in the upstream direction) with the implicit assumption that present traffic is more downstream-oriented.

Emerging web applications require unprecedented bandwidth, exceeding the capacity of traditional VDSL or CATV technologies. The explosive demand for bandwidth is leading to new access network architectures which are bringing the high-capacity optical fiber closer to the residential homes and small businesses [3]. The FTTx models – Fiber to the Home (FTTH), Fiber to the Curb (FTTC), Fiber to the Premises (FTTP), etc. – offer the potential for unprecedented access bandwidth to end users (up to 100 Mbps per user). These technologies aim at providing fiber directly to the home, or very near the home, from where technologies such as VDSL or wireless can take over. FTTx solutions are mainly based on the Passive Optical Network (PON). Developments in PON in recent years include Ethernet PON (EPON), ATM-PON

Manuscript received 2 October 2008; revised 1 March 2009.

H. Song and B. Mukherjee are with Department of Computer Science, University of California, Davis, CA 95616, USA (e-mail: song@cs.ucdavis.edu, mukherjee@cs.ucdavis.edu).

B. Kim is with Electronics and Telecommunication Research Institute (ETRI), Daejeon, Korea (e-mail: kbw@etri.re.kr).

Digital Object Identifier 10.1109/SURV.2010.020110.00040.

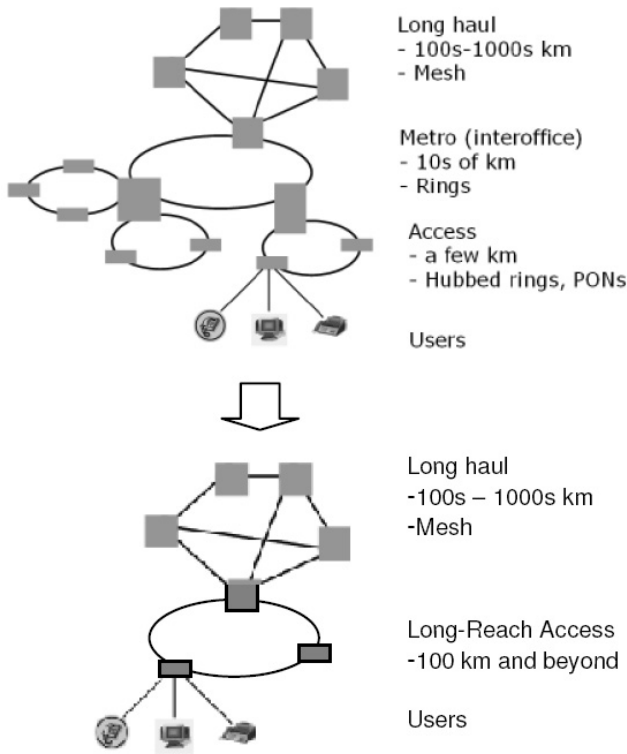

Fig. 1. LR-PON simplifies the telecom network [1, 2].

(APON, based on ATM), Broadband-PON (BPON, based on APON, adding support for WDM and higher bandwidth), Gigabit-PON (GPON, an evolution of BPON, supporting higher rates and multiple layer-2 protocols), and wavelength-division-multiplexing PON (WDM-PON) [6, 7, 8, 9]. Recently investigation shows broadband access is penetrating quickly into residential and business users, e.g., fiber connections account for 36% of all Japanese broadband subscriptions and 31% in Korea [10], and the Australian Government's "BroadbandNow" project promises to deploy in five years broadband access nationwide.

PON reduces the network cost by eliminating the power supply (operational cost) along the fiber path from Central Office (CO) to end users, and by sharing the significant portion of the network cost among multiple users. However, the cost reduction offered by a PON might not be enough for the future telecom network, e.g., research shows the realization of fiber access throughout United Kingdom would cost around £15 billion. The economic driver behind technology calls for a new thinking on the broadband optical access.

An alternative technology, called Long-Reach Passive Optical Network (LR-PON), was proposed as a more cost-effective solution for the broadband optical access network. LR-PON extends the coverage span of PONs mentioned above from the traditional 20 km range to 100 km and beyond by exploiting Optical Amplifier and WDM technologies. A general LR-PON architecture is composed by an extended shared fiber connecting the CO and the local user exchange, and optical splitter connecting users to the shared fiber. Compared with traditional PON, LR-PON consolidates the multiple Optical Line Terminals (OLTs) and the Central Offices (COs)

where they are located, thus significantly reducing the corresponding Operational Expenditure (OpEx) of the network. By providing extended geographic coverage, LR-PON combines optical access and metro into an integrated system. Thus, cost savings are also achieved by replacing the Synchronous Digital Hierarchy (SDH) with a shared optical fiber. In general, the LR-PON can simplify the network, reducing the number of equipment interfaces, network elements, and even nodes.

Although the idea of extending the reach of a PON has been around for quite a while, it is emphasized recently because the optical access is penetrating quickly into residential and small-business markets and the simplification of telecom network requires an architecture to combine the metro and access networks. Figure 1 shows how LR-PON simplifies the telecom network. The traditional telecom network consists of the access network, the metropolitan-area network, and the backbone network (also called long-haul or core network). However, with the maturing of technologies for long-reach broadband access, the traditional metro network is getting absorbed in access. As a result, the telecom network hierarchy can be simplified with the access headend close to the backbone network. Thus, the network's Capital Expenditure (CapEx) and Operational Expenditure (OpEx) can be significantly reduced, due to the need for managing fewer control units. But this architecture also brings with it its own new research challenges, which will be outlined in this paper.

The rest of this paper is organized as follows. Section II discusses the research challenges in the Long-Reach PON design. Section III summarizes some relevant Long-Reach PON demonstrations worldwide by different research institutes. Section IV discusses the Dynamic Bandwidth Allocation algorithms in Long-Reach PON. Section V concludes the paper.

## II. RESEARCH CHALLENGES

Figure 2 shows the general architecture of a LR-PON. The central office (CO) connects the core network and the access network, and implements layer 2 and layer 3 functions, e.g., resource allocation, service aggregation, management, and control. The local exchange resides in the local users' area, which is close to the end customer equipment: ONU (within 10 km of drop section). The optical signal propagates across the fiber forming the feeder section (100 km and beyond) with the CO and the local exchange at its two ends; then the fiber is split and connected to a large number of ONUs. In order to compensate for the power loss due to long transmission distance and high split size, optical amplifiers are used at the OLT and the local exchange.

### A. Signal Power Compensation

Optical amplification is indispensable in a LR-PON. Besides amplifying the signal, the amplifiers introduce two challenges, as indicated below.

1) : Optical amplifiers introduce amplified spontaneous emission (ASE) [11]. ASE is a side effect of the amplification mechanism, produced by spontaneous emission that has been optically amplified by the process of stimulated emission in a gain medium. The ASE may have a detrimental effect on

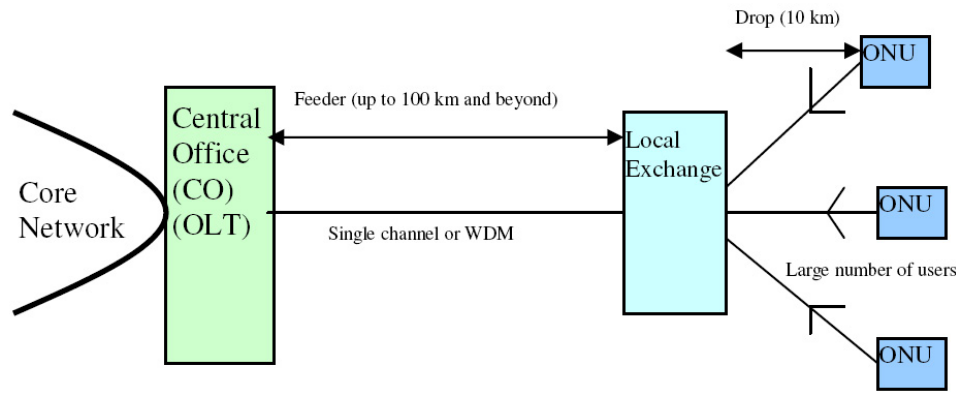

Fig. 2. Long-Reach PON (LR-PON) architecture.

system performance. As the high split of LR-PON would attenuate the signal power significantly, the input signal at the amplifiers could be sufficiently low. Meanwhile the ASE noise is device-dependent, e.g., ASE noise usually accumulates with the length of Erbium-doped fiber (EDF) and noise figure of an ideal Erbium-doped-fiber amplifier (EDFA) is 3 dB [11]. As a result, the signal-to-noise ratio (SNR) could be reduced significantly. In order to amplify the optical signal while suppressing the noise, a possible scheme, called dual-stage intermediate amplification, was introduced [18]. In this scheme, the first stage amplification is composed of a low-noise pre-amplifier, which produces a high SNR by maintaining its ASE at a low level; and the second stage consists of amplifiers with enough power to amplify, in order to counter the large attenuation in the feeder section (100 km and beyond).

2) : As a widely used optical amplifier, the EDFA features a low noise figure, a high power gain, and a wide working bandwidth, which enable it to be advantageous in a LR-PON employing WDM. But the relatively slow speed in adjusting its gain makes it disadvantageous due to the bursty nature of upstream time-division-multiple-access (TDMA) traffic in a LR-PON, where the optical amplifier needs to adjust its gain fast when packets with different DC levels due to different ONU distances pass through it, in order to output packets with uniform signal amplitude. A possible solution called gain control uses optical gain clamping or pump power variation, e.g., using an auxiliary wavelength that senses the payload wavelength and adjusting relatively to the transmitted upstream packet so that the total input power at the EDFA remains constant. Hence, the gain of the EDFA remains constant for the burst duration. Researchers have also investigated the semiconductor optical amplifier (SOA) as the amplifier [11, 12], for its advantages to be adjusted faster and offer the potential for monolithic or hybrid array integration with the other optical components. Although the relatively narrow working bandwidth of SOA operates on a per-channel basis, this single-channel SOA is suitable for the "pay as you grow" business model [17].

### B. Optical Source

In order to lower the CapEx and OpEx, a standard PON may choose lower-cost uncooled transmitters in the ONU, because a major investment for an optical access network is the

cost associated with installation of an optical transmitter and receiver in the ONU at the customer premises [3]. However, the uncooled transmitter is temperature dependent; as a result, it could transmit a wavelength with a possible drift of 20 nm [13]. In a standard PON, the performance may be unaffected as no component is wavelength critical. But in a LR-PON which exploits WDM to satisfy the huge amount of traffic, the wavelength drift becomes crucial, especially for certain components such as optical filters. To counter the wavelength drift, more expensive cooled transmitters are considered to ensure a stable wavelength. A possible technology is called reflective ONU (R-ONU) [24], which generates the upstream signal from the optical carrier feeding from outside (could be the downstream optical carrier or a shared optical source at the local exchange), using a reflective SOA (RSOA) modulator.

The transmitters in a traditional PON are usually designed for a transmission range which is less than 20 km. The challenge arises when applying them in a LR-PON where the signal needs to cover a range of 100 km and beyond.

### C. Burst-Mode Receiver

The different ONU-OLT distances mean different propagation attenuations for signals from ONUs to the OLT, which in turn result in varied DC levels of bursty packets from the ONUs at the OLT. A burst-mode receiver is designed for this circumstance. It includes the automatic gain control (AGC) for adjusting its 0-1 threshold at the beginning of each received burst, and the clock and data recovery (CDR) for acquiring phase and frequency lock on an incoming signal. The design of burst-mode receiver at 1 Gbps has been addressed in the context of IEEE 802.3ah EPON networks, and the one at 10 Gbps or 10 G / 1 G hybrid is currently discussed in IEEE 802.3av 10 Gbps EPON. An LR-PON scales up in speed (10 Gbps and beyond) and number of customers supported (up to 512 users could share the same channel), challenges might occur in the following aspects. As the optical amplifier increases the difference of the DC level of upstream signals from different ONUs, the burst-mode receiver is required to support a wider dynamic range; as the signal power may be attenuated significantly due to a large split ratio and a long-distance transmission, the burst-mode receiver is required a high sensitivity; and with the increased sharing ratio of the same channel, a more strict timing control of the guard time

between successive ONU transmission slots is required, in order to achieve a higher bandwidth efficiency. Efforts have been made by researchers, such as a new 10 Gbps burst-mode receiver [26] that uses a multi-stage feed-forward architecture to reduce DC offsets, and a high sensitivity avalanche photodiode (APD) burst-mode receiver [14] for 10 Gbps TDM-PON systems.

#### D. Upstream Resource Allocation

In LR-PON, the end users and the Central Office (CO) (through which users are connected to the rest of the Internet) are separated by a significant distance, typically 100 km and beyond. Hence, control-plane delays (ONUs send transmission request to CO, and transmit upstream data upon receiving acknowledgement from CO) are significant. Meanwhile, the delay budget in an access network is approx. 1-2 milliseconds for real-time applications. In order to mitigate the effect of the control-plane delay, efficient remote-scheduling algorithms (e.g., dynamic bandwidth allocations) need to be developed which overcome the large CO-user distance, which support different classes of service, and which are scalable in terms of the number of users supported as well. We will discuss some research endeavors in Section IV.

#### E. Topology and Protection

Several candidate network topologies have been proposed for LR-PON. For example, the branch-and-tree topology has a feeder section of a strand of fibers of 90 km (tree) and is split to multiple users (branches) at the local exchange; while the ring-and-spur topology has the feeder section composed by a fiber ring and Optical Add-Drop Multiplexers (OADMs) [1] on the ring, and up and downstream optical signals are added and dropped through OADMs and split to end users [27]. As LR-PON exploits the huge transmission capacity of optical technology, and is oriented for long-range coverage to serve a large number of end users, any network failure may cause a significant loss for customers and the network operator. The LR-PON protection becomes necessary and important. Various protection schemes for PONs have been proposed by ITU-T (e.g., G. 983 and G. 984). But protection schemes on emerging topologies, such as ring-and-spur topology need further investigation. Section III.D will introduce a protection scheme for the ring-and-spur topology.

### III. DEMONSTRATIONS OF LR-PON

#### A. PLANET SuperPON

The ACTS-PLANET (Advanced Communication Technologies and Services - Photonic Local Access NETWORK) [15 - 21] is an EU-funded project. This project investigated possible upgrades of a G.983-like APON system in the aspect of network coverage, splitting factor, number of supported ONUs, and transmission rates. Note that the term SuperPON is not fully accurate since not all of its components between the OLT and ONUs are passive; but this term has been used quite widely in the literature to show the SuperPON's derivation from the traditional PON system with the use of limited active elements.

The basic architecture is depicted in Fig. 3, which was installed in the first quarter of 2000. The implemented system supports a total of 2048 ONUs and achieves a span of 100 km. The 100-km fiber span consists of a maximum feeder length of 90 km and a drop section of 10 km. The large splitting factor is achieved through 2-stage splitting at the local exchange and drop section.

The increased transmission range from 20 km to 100 km and split size from 32 to 2048 increases the signal attenuation. To compensate for the attenuation, optical amplifiers are located at the feeder section (feeder repeater) and at the intersection between the feeder and the drop sections (amplified splitter). In the downstream direction, EDFAs are chosen as the amplifier because of their high power gain, wide working bandwidth, and the continuous wave mode of downstream signal. The cost of amplifiers is shared among the end users due to the downstream broadcast property, which makes it less cost-sensitive.

In the upstream direction, due to the possibly unequal distances between the OLT and the ONUs, optical signal attenuation may not be the same for each ONU. As a result, the power level received at the OLT may be different (burst mode) for each ONU. PLANET chooses SOAs to amplify the burst-mode upstream signals. The SOAs are not only placed at the output of the splitter in the local exchange, but also included in parallel between split stages, in order to reduce the split loss before the signal is attenuated by a split. Otherwise, if SOAs are only placed after the splitter, the signal-to-noise ratio (SNR) cannot satisfy the system requirements (an SNR  $\geq 18.6$  dB was required to achieve the PLANET target performance bit-error rate (BER) of  $10^{-9}$ , using ON-OFF keying and including a 3-dB optical power margin [16]). But a side effect, named noise funneling, is introduced due to the placement of SOAs, because the ASE contribution from the SOAs in parallel is combined and make the effect of ASE more severe. In order to remedy this effect, the Operation, Administration, and Maintenance ONU (OAM-ONU) is introduced. It receives and interprets all downstream control information. In this way, it can calculate information on which ONUs are granted access to the upstream path at a certain instant in time. Using this information, the protocol switches on an SOA when it is required to amplify the corresponding upstream signal, with a switching transient lower than 25 ns.

The transport system is based on Asynchronous Transfer Mode (ATM), which offers 2.5 Gbps and 311 Mbps for downstream and upstream transmissions. A Time-Division Multiple Access (TDMA) protocol is used to allocate the upstream bandwidth among multiple users. Besides synchronizing the ONUs' transmission, the protocol also enables OAM-ONU to synchronize the SOAs to set the correct gain to compensate for different power losses of upstream signals from different ONUs.

Other possible architectures for PLANET are discussed in [18], which use different types of amplifiers. Detailed calculation on the effect of accumulated ASE noise of the amplifiers is included in [20].

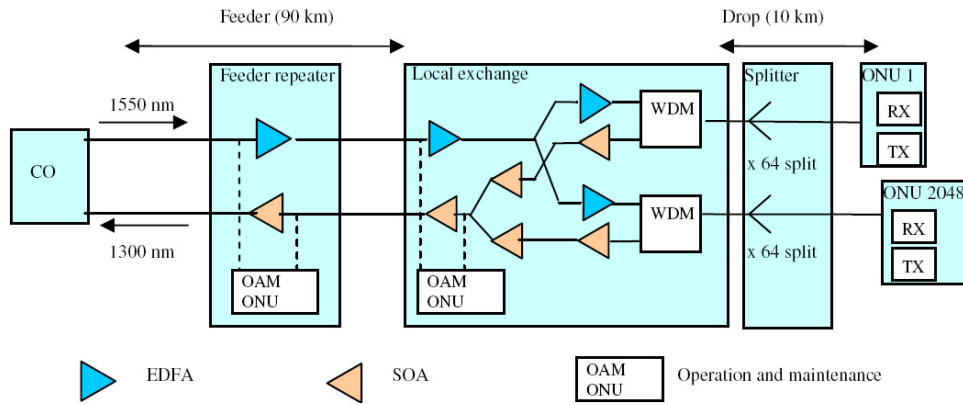

Fig. 3. ACTS-PLANET architecture and transport system [15-21].

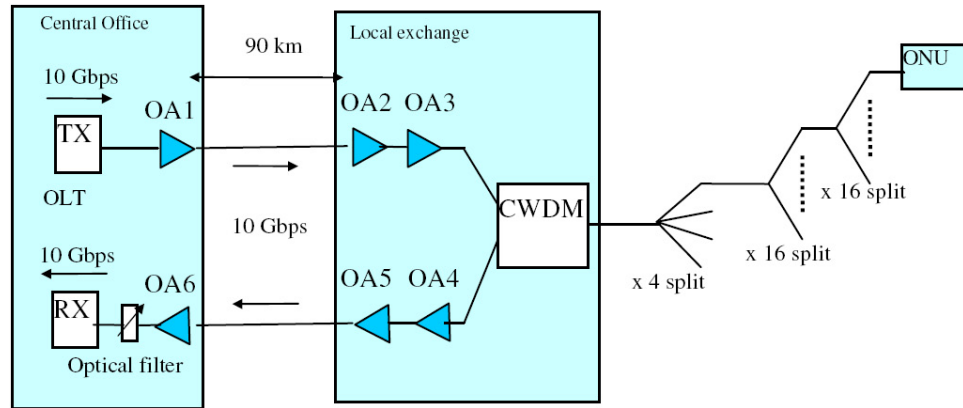

Fig. 4. Long-reach optical access network by British Telecom [22].

### B. Demonstrations from British Telecom (BT)

British Telecom has demonstrated its Long-Reach PON, which is characterized by a 1024-way split, 100-km reach, and 10-Gbps transmission rate for upstream and downstream directions [22]. Compared with SuperPON above, the split size has been halved. This brings a major benefit by saving the amount of optical amplifiers needed, e.g., 6 optical amplifiers are enough for up and down streams as opposed to 39 required by SuperPON. The 1024-way split is made up of a cascade of two N:16 and one N:4 splitters in the drop section.

The system includes a 90-km feeder section between the OLT and the local exchange, and a 10-km drop section between the local exchange and end users. In order to boost the signal attenuated by large splitting and long-distance transmission, optical amplifiers are used at the OLT and the local exchange.

In order to lower the CapEx and OpEx of LR-PON, the ONU for the large number of end users has to be simple and cost efficient. As a result, the transmitter output power in an ONU is constrained because it is a key price factor for the optical transmitter. Besides the constrained signal power, the drop section has a large power loss of 40.3 dB before the signal is amplified. Hence, a very low signal power will arrive at the local exchange. To boost the signal to enough power, a two-stage amplifier as discussed in Section II is implemented, which contains (1) a low-noise pre-amplifier which produces a high SNR by maintaining its ASE at a low

level, and (2) second-stage amplifiers to amplify the optical signal with enough power.

Other technologies used include forward error correction (FEC) and optical filter. FEC is a coding technique by which transmission errors can be detected and corrected by encoding the data and including a number of parity bits. FEC can alleviate the system design requirement by allowing a relatively higher pre-FEC BER, e.g., a BER of  $10^{-10}$  required by a LR-PON only needs a pre-FEC BER of  $2.9 \times 10^{-4}$ . Optical filter can also promote the SNR of the received signal by reducing the ASE noise in the signal passing through.

The above demonstration [22] concerned mainly the physical layer to extend the access network, e.g., power budget. However, a later demonstration [23] (Fig. 5) showed how to integrate the higher-layer issues, e.g., control protocol into LR-PON design. This demonstration extended gigabit PON (GPON) from 20 km to 135 km, and integrated WDM to increase the system capacity.

The experimental configuration in Fig. 5 shows an extended GPON with 40-channel WDM system. The OLT transmits downstream at a wavelength in the 1490-nm region, according to GPON standard. The data rate for each downstream channel is 2.488 Gbps. This downstream wavelength will be converted to a WDM-compatible wavelength of 1552.924 nm by a transponder right after the OLT. The conversion is necessary because the long-distance transmission exploits a WDM system of 125-km standard G.652 fiber with an EDFA

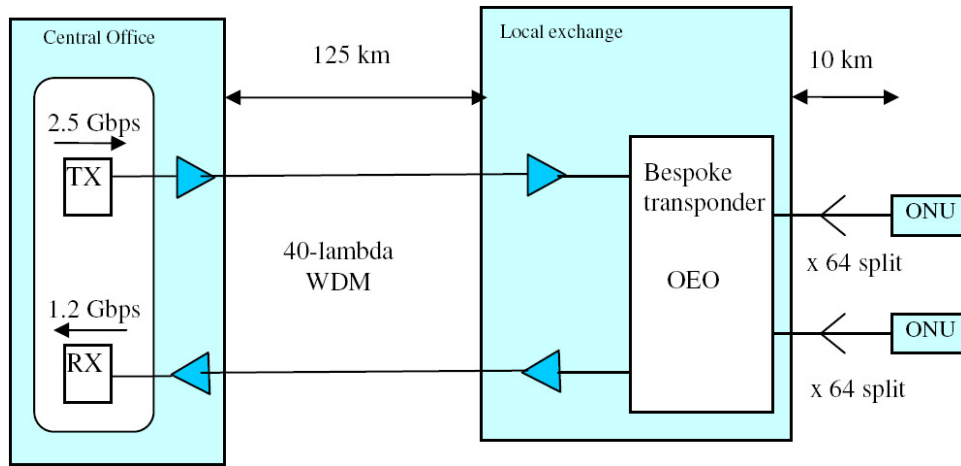

Fig. 5. Experimental configuration of GPON extended to 135 km via WDM [23].

attached to each end. When arriving at the drop section, the wavelengths are converted back to 1490-nm range through a bespoke transponder for compliance with the GPON standard. Then, each wavelength is split to 64 ONUs within the 10-km drop section.

The experiment demonstrates GPON ONUs with different upstream wavelength ranges in the upstream direction: 1310 nm or 1550 nm. These different wavelengths have the same transmission rate of 1.244 Gbps, and will be converted at the bespoke transponder to a WDM-compatible wavelength of 1559.412 nm. At the OLT side, an optical filter is placed before the burst-mode receiver to improve the SNR. Due to the incorporation of the optical filter, the temperature control of the system must be precise in order to prevent wavelength drift.

The demonstration achieved a BER better than  $10^{-10}$  in both directions. It also demonstrated that, by using optical-electrical-optical (OEO) conversion at the transponder and optical amplification, the GPON can be extended to beyond 100-km range.

### C. Demonstrations from University College Cork, Ireland

The demonstration of a hybrid WDM-TDM LR-PON is reported in [24, 25] by the Photonic System Group of University College Cork, Ireland. This work supports multiple wavelengths, and each wavelength pair (up and down stream) can support a PON segment with a long distance (100 km) and a large split ratio (256 users).

The layout in Fig. 6 is divided into four notional locations: 1) customer ONU, 2) street cabinet, 3) local exchange, and 4) core exchange. The core and local exchange are powered to support signal amplification on both ends of the long-distance fiber transmission (88 km). The street cabinet contains cascaded optical splitters to achieve a large split size of 256 in each TDM-PON segment. As WDM requires precise wavelength control (50 GHz or 100 GHz channel spacing), a WDM centralized source is placed at the local exchange, which is composed of an array of distributed feedback (DFB) laser diodes to generate upstream carrier wavelengths. These upstream carrier wavelengths are split and fed to each ONU through the street cabinet. The customer ONU is colorless

which uses a semiconductor electro-absorption modulator (EAM) to modulate the upstream carrier wavelength generated in the local exchange, and two SOAs are connected to the input and output of EAM to amplify the upstream wavelength before and after the modulation.

Each up and down stream wavelength has a transmission rate of 10 Gbps. These wavelengths are achieved by WDM channel allocation, where the C-band is split into two segments: the blue half (1529 - 1541.6 nm) carrying downstream channels and the red half (1547.2 - 1560.1 nm) carrying upstream channels. The red and blue bands are separated by a guard band of approximately 5 nm. With 100-GHz channel spacing, 17 pairs of up and down channels can be achieved to support 17 PON segments in the demonstration.

The demonstration offers a LR-PON with 17 PON segments, each of which supports symmetric 10-Gbps upstream and downstream channels over a 100-km transmission. The system can serve a large number of users ( $17 \times 256 = 4352$  users). Experiments show a low BER of  $10^{-9}$  in both directions.

In order to scale the long-reach access network, the authors in [26] cooperated with British Telecom and other telecom companies, e.g., Alcatel and Siemens, to demonstrate their second-stage prototype: Photonic Integrated Extended Metro and Access Network (PIEMAN) sponsored by the Information Society Technologies (IST) Sixth Framework Project. As shown in Fig. 7, PIEMAN consists of a 100-km transmission range with 32 DWDM channels supported, each of which operates at a symmetric 10 Gbps and serves a PON segment. The split ratio for each PON segment is 512, which means that the maximum number of users supported is  $32 \times 512 = 16,384$ .

At the local exchange, the downstream wavelengths are pre-amplified by the EDFA, and then demultiplexed into the single wavelengths through Arrayed Waveguide Grating (AWG). Then, each single wavelength is amplified by a single-wavelength EDFA. This configuration shows better performance and cost efficiency compared with the one which only has a powerful EDFA before the AWG. For the upstream direction, each upstream wavelength before entering the AWG is amplified by a single-wavelength EDFA which is stabilized



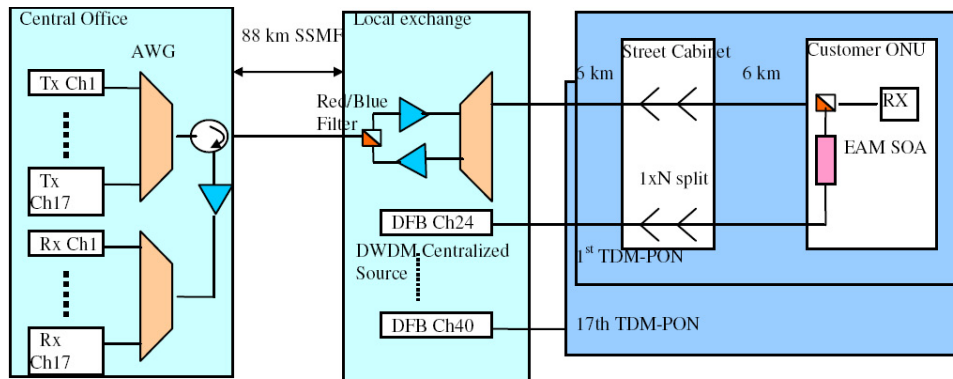

Fig. 6. Hybrid DWDM-TDM long-reach PON architecture [24, 25].

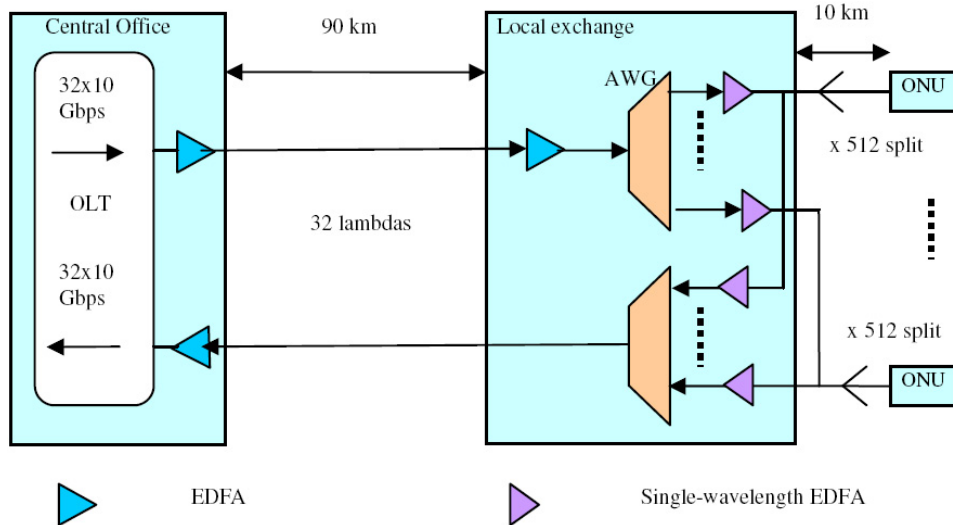

Fig. 7. PIEMAN hybrid WDM/TDMA architecture [26].

against the transients introduced by bursty traffic. A common upstream WDM EDFA at the local exchange is not used in order to avoid the transients by neighboring channels.

Other key issues in PIEMAN include the 10-Gbps burst-mode receiver and colorless ONU. The design of the 10-Gbps burst-mode receiver is composed of a burst-mode trans-impedance amplifier with PIN photodiode and a burst-mode post-amplifier to accommodate the high bit rate and the high dynamic range imposed by the high split and the ASE introduced by the amplifiers. The colorless ONU attempts to reduce the cost of the ONU by removing the need for an internal wavelength referring and control function. Instead, the ONU remodulates the downstream optical carrier distributed from the central office, using the "colorless" reflective modulators that operate across the full upstream bandwidth range to generate the upstream signal.

#### D. Demonstrations of "Ring-and-Spur" LR-PON

Instead of the "tree-and-branch" topology considered in the prior approaches, researchers are also investigating a "ring-and-spur" topology for LR-PON, as shown in Fig. 8, where each PON segment and OLT are connected through a fiber ring, and each PON segment can exploit traditional FTTX technology with a topology consisting of several "spurs"

served from the "ring". The ring can cover a metro area up to 100 km and traditional users in an access area can be served by a spur segment. The natural advantage of the ring topology is that it provides two-dimensional coverage, as well as failure protection, e.g., traffic can choose its transmission in an alternate direction to avoid a fiber cut.

An example demonstration is by ETRI, a Korean government-funded research institute, which has developed a hybrid LR-PON solution, called WE-PON (Wdm-E-PON) [27]. In WE-PON, 16 wavelengths are transmitted on the ring, and they can be added and dropped to local PON segments through the remote node (RN) on the ring. A possible design of the RN includes OADM and optical amplifiers. As the split ratio of the splitter is 1:32, the system can accommodate 512 users.

Another demonstration [28, 29], named Scalable Advanced Ring Dense Access Network Architecture (SARDANA), also implements the "ring-and-spur" topology. Thirty-two wavelengths are transmitted on the ring with a splitting factor of 1:32 for each wavelength. Over 1000 users are supported. ONUs are based on 1.25/2.5/5 Gbps-capable RSOA and downstream at 10 Gbps. It also proposes a protection design in the RN, which enables the RN to receive signals from east or west fiber connection. So, in case of failure, RN can choose

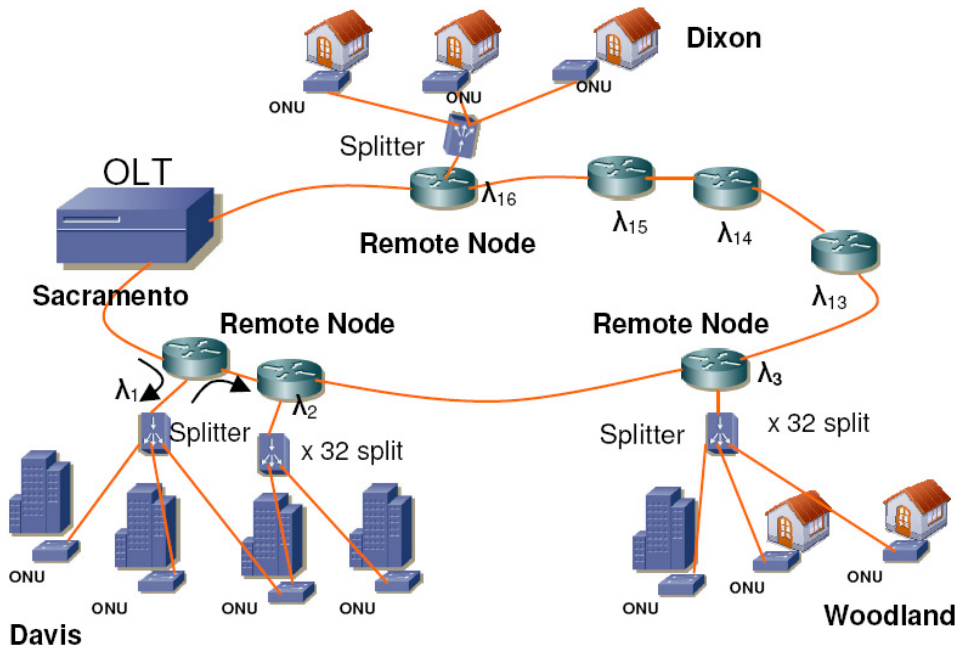

Fig. 8. WE-PON in FTTH topology [27].

to receive from the direction in which it still connects with the CO.

#### E. Other Demonstrations

Recently, more demonstrations of LR-PON have appeared in the literature [30-33]. In [30], the authors proposed a ring-and-spur WDM-TDM access network architecture, named Stanford University Access (SUCCESS). SUCCESS employs a semipassive configuration of remote nodes to enable protection and restoration, and fast tunable lasers at the OLT provide down and up channels which can be shared by all ONUs to reduce the transceiver count.

Another demonstrator [31], named STARGATE, examines an optically-integrated access-metro network. STARGATE employs a hybrid structure of a ring-and-spur network and a long-reach star subnet connecting each remote node. This structure allows ONUs of different PONs to communicate directly without OEO conversion at any intermediate CO, and it can easily allocate a new channel to an upgraded user in a pay-as-you-grow manner. The well-designed remote node supports space dimension and optical bypass, which allow dynamic setup of fine-granularity transparent connections between ONUs in different WDM PONs in support of emerging applications (e.g., P2P file sharing).

Some research demonstrates possible network configurations in terms of span and capacity, e.g., 512-ONUs-100 km, 1024-ONUs-100 km [32], and a 85-km LR-PON using a reflective SOA-EA modulator at 7.5 Gbps [33], then a 120-km LR-PON with symmetric up and down data rate of 10 Gbps [34].

Other endeavors incorporate novel devices or technologies. An SOA-Raman Hybrid Amplifier [35, 36] (SRHA) with an ultra broadband gain (up to 80-nm bandwidth) is introduced, in which the SOA provides the bulk of the gain while the Raman stage compensates for the SOA's gain tilt, resulting in

a broad relatively flat gain. The test bed incorporating SRHA provides symmetric baseband services at 2.488 Gbps over 60 km (1490 nm down and 1310 nm up) with a 1:64 split and has 3 downstream video enhancement wavelengths at 1510 nm, 1530 nm, and 1550 nm.

An innovative bi-directional amplification is proposed to offer an amplification scheme of LR-PON in a cost-effective manner [37]. The bi-directional amplification is realized by using a novel four-port interleaver to direct the up and downstream wavelengths through the same optical amplifier. The test shows a power penalty of less than 0.8 dB after 100-km standard single-mode fiber (SSMF) transmission for all channels at 10 Gbps.

A hybrid WDM-CDM (Code Division Multiplexing)-PON scheme is proposed in [38], trying to eliminate the optical amplifier through the coding gain of CDM. The test shows a 42-dB loss budget for transmitting 16 symmetric 2-Gbps channels for 100 km distance, with a 1x32 split at the user side. The authors in [39, 40] also demonstrate a 35-channel LR-PON over 70-km single mode fiber, without using the optical amplifier. It is achieved because the mode control and low front-facet reflectivity of the Fabry-Perot laser diodes (F-P LDs) at the OLT and ONUs enable the long-reach transmission without optical amplifier.

The network structure in [41] employs wavelength converters at user premise to convert upstream wavelength from ONU to OLT before it is transmitted on the long-haul fiber. Thus, the ONU can choose inexpensive un-cooled lasers to decrease system cost. The demonstration provides 38.8 Mbps per user to potentially 1280 users over a distance of 120 km.

As a summary, we list the main demonstrations and their characteristics in Table 1.

#### IV. DYNAMIC BANDWIDTH ASSIGNMENT (DBA)

As multiple ONUs may share the same upstream channel, DBA is necessary among ONUs. Considering the LR-PON's



TABLE I  
TYPICAL DEMONSTRATIONS OF LONG-REACH BROADBAND ACCESS NETWORKS.

Project	Base type	Reach(km)	Wavelengths	Down/up/wavelength(Gbps)	ONUs
ACTS-PLANET [15-21]	APON	100	1	2.5/0.311	2048
B.T. [22, 23]	GPON	135	40	2.5/1.25	2560
WDM-TDM [24, 25]		100	17	10/10	4352
PIEMAN [26]		100	32	10/10	16,384
WE-PON [27]	G&EPON	100	16	2.5/2.5	512
SARDANA [28, 29]	G&EPON	100	32	10/2.5	1024

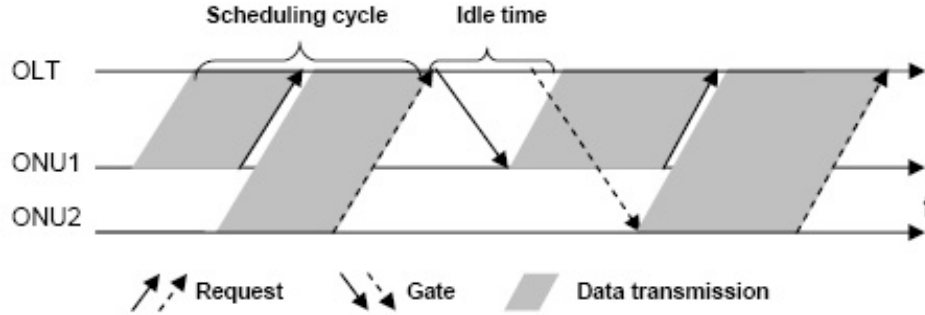

Fig. 9. An example of single-thread polling with stop.

benefits in CapEx and OpEx, as well as its derivation from the traditional PON, the upstream bandwidth allocation is controlled and implemented by the OLT.

Two kinds of bandwidth allocation mechanisms are used in PON: status-reporting mechanism and non-status-reporting mechanism. In non-status-reporting, the OLT continuously allocates a small amount of extra bandwidth to each ONU. If the ONU has no traffic to send, it transmits idle frames during its excess allocation. Observing a large number of idle frames from the given ONU, the OLT reduces its bandwidth allocation accordingly; otherwise, OLT increases its bandwidth allocation when observing that the given ONU is not sending idle frames. Although this mechanism has the advantage of imposing no requirements on an ONU and no need for the control loop between OLT and ONU, there is no way for the OLT to know how best to assign bandwidth across several ONUs that need more bandwidth. We then focus on the status-reporting mechanism in the rest of this section.

To support the status-reporting mechanism and DBA arbitration in the OLT, the proposed DBA algorithms in LR-PON are based on the Multi-Point Control Protocol (MPCP) specified in the IEEE 802.3ah standard. Before explaining the DBA algorithms, we briefly introduce MPCP.

MPCP is not concerned with a particular bandwidth-allocation (or inter-ONU scheduling) scheme; rather, it is a supporting mechanism that can facilitate implementation of various bandwidth-allocation algorithms in PON. This protocol relies on two specific messages: GATE and REPORT. (Additionally, MPCP defines REGISTER\_REQUEST, REGISTER, and REGISTER\_ACK messages used for an ONU's registration). A GATE message is sent from the OLT to an ONU, and it is used to assign a transmission timeslot (bandwidth). A REPORT message is used by an ONU to convey its local conditions (such as buffer occupancy and the like) to the OLT to help the OLT make intelligent allocation decisions. Both GATE and REPORT messages are MAC

(media access control) control frames and are processed by the MAC control sublayer.

The proposed DBA algorithms work in conjunction with MPCP. The OLT has to first receive all ONU REPORT messages before it imparts GATE messages to ONUs to notify them about their allocated timeslot. As a result, the upstream channel will remain idle between the last packet from the last ONU transmission in a polling cycle  $k$  and the first packet from the first ONU transmission in polling cycle  $k+1$ , as shown in Fig. 9. Here the polling cycle is the time period (or cycle) in which ONUs transmit sequentially. This idle time equals to the Round-Trip Time (RTT) which is needed for the control messages to propagate along the path ONU ' OLT ' ONU. In a traditional PON, this idle time is negligible because its RTT is only 0.1 ms with 10-km span. LR-PON increases the RTT to 1 ms with 100 km of OLT-ONU distance, which results in 10x the idle time in a traditional PON.

In order to combat the detrimental effect of the increased RTT, the work in [42] proposed the Multi-Thread Polling algorithm, in which several polling processes (threads) are running in parallel, and each of the threads is compatible with the proposed DBA algorithms in traditional PON. Figure 10 shows an example of Multi-Thread Polling (two threads are shown in the example) and compares it with traditional DBA algorithms (so-called one-thread polling with stop). As shown in Fig. 10, the idle time is eliminated because, when ONUs wait for GATE messages from OLT in the current thread which incurs idle time in one-thread polling, they can transmit their upstream packets which are scheduled in another thread simultaneously. Note that ONU1 and ONU2 in the illustration may not be the exact ones shown in our mentioned demonstrations. They apply to ONUs who share the same upstream wavelength.

The research in [43] also proposed a two-state DBA protocol for LR-PON. The two states include a normal-state cycle shown as yellow color in Fig. 11, and a virtual-state cycle

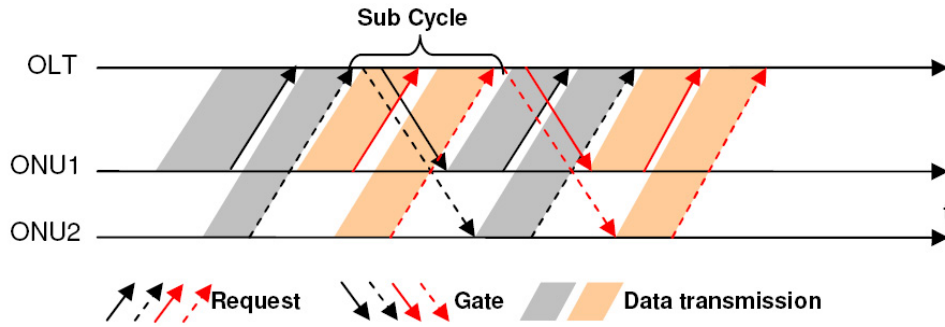

Fig. 10. An example of multi-thread polling [42].

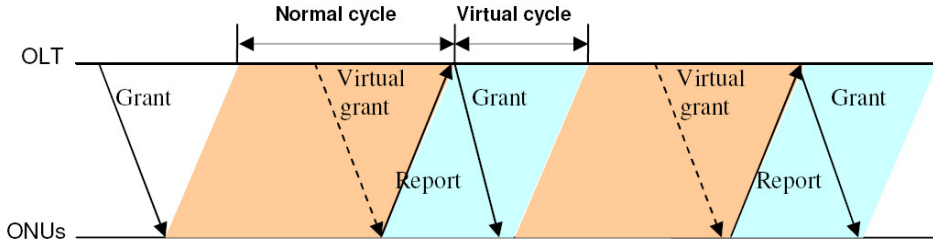

Fig. 11. A two-state DBA protocol for LR-PON [43].

shown as blue color in Fig. 11. The normal cycle implements DBA through status-reporting mechanism, and leaves an idle timeslot between successive transmission slots. Accordingly, the idle timeslots will constitute virtual polling cycles, during which the ONUs can transmit data by means of a prediction method to estimate their bandwidth requirement, as shown in Fig. 11.

## V. CONCLUSION

Long-Reach Passive Optical Network (LR-PON) exploits the huge transmission capacity of optical technology, and is oriented toward long-range transmission and a large user base. LR-PON is anchored at a Central Office (CO), so that all higher-layer networking functions can now be located further upstream in the "network cloud". The OLTs of the traditional PON (which used to sit approx. 10–20 km from the end user) can now be replaced at the local exchange by some elementary hardware, which contains a small amount of compact low-power physical-layer repeater equipment, such as optical amplifiers and Optical Add-Drop Multiplexer (OADM). As a result, the telecom network hierarchy can be simplified with the access headend closer to the backbone network. Thus, the network's Capital Expenditure (CapEx) and Operational Expenditure (OpEx) can be significantly reduced.

In this paper, we discussed the research challenges related to LR-PON, from the physical layer, e.g., power attenuation, to the upper layer, e.g., bandwidth assignment. We reviewed some existing LR-PON demonstrations: PLANET SuperPON initiated the research on LR-PON and extended the network reach based on the APON model; BT's demonstrations increased the network capacity up to 10 Gbps per channel and incorporated WDM based on a GPON model; and PIEMAN further exploited the huge optical transmission capacity to support up to 16,384 users. WE-PON offered a novel ring-and-spur topology to provide a better two-dimensional geograph-

ical coverage and protection for PON traffic by using a ring. Several other demonstrations were also discussed. The impact of increased RTT on higher-layer control was also discussed. Dynamic bandwidth allocation (DBA) algorithms, e.g., multi-thread polling and two-state DBA, have been proposed to remedy the impact of long propagation delay by utilizing the idle time between transmission cycles.

A number of new technologies and designs are developing the LR-PON towards a higher-capacity system - from a single wavelength to WDM, from less than Gbps transmission speed, e.g., 311 Mbps in PLANET to 10 Gbps symmetric transmission, e.g., PIEMAN. GPON and EPON protocols will be naturally inherited and be adjusted for the LR-PON, since they are mature standards in PONs today. LR-GPON may be preferred by US and some European countries because many of their national carriers choose GPON as first-mile solution, e.g., BT and Verizon. LR-EPON may be a choice of the Asian countries since EPON is preferred there. Introducing LR-PON into practical use will be a gradual process. As a first step, network operators need the LR-PON to cover the "green field" without establishing a new OLT [44]. Then, with the consolidation of OLTs and the merging of access and metro, we are expecting ubiquitous LR-PONs.

## REFERENCES

- [1] B. Mukherjee, *Optical WDM Networks*, Springer, Feb. 2006.
- [2] O. Gerstel, "Optical Networking: A Practical Perspective," *IEEE Hot Interconnects*, Aug. 2000.
- [3] NSF Workshop Report, "Residential Broadband Revisited: Research Challenges in Residential Networks, Broadband Access, and Applications," Oct. 2003. <http://cairo.cs.uiuc.edu/nsfbroadband/>
- [4] M. Wegleitner, "Maximizing the Impact of Optical Technology," Keynote Address, *Proc. IEEE/OSA Optical Fiber Communication Conference (OFC'07)*, Anaheim, CA, Mar. 2007
- [5] Gartner Report, "One Gigabit or Bust Initiative, A Broadband Vision for California," 2003. <http://www.cenic.org/GB/gartner/>

- [6] A. Banerjee, Y. Park, F. Clarke, H. Song, S. Yang, G. Kramer, K. Kim, and B. Mukherjee, "Wavelength-Division Multiplexed Passive Optical Network (WDM-PON) Technologies for Broadband Access: A Review [Invited]," *OSA J. Optical Networking*, vol. 4, no. 11, pp. 737-758, Nov. 2005.
- [7] R. Lauder, "Technology and Economics for Coarse Wavelength Multiplexing Workshop," *Proc. IEEE/OSA Optical Fiber Communication Conference (OFC'04)*, Los Angeles, CA, 2004.
- [8] J. George, "Designing Passive Optical networks for cost effective triple play support," *Proc. FTTH Conference*, 2004.
- [9] G. Agrawal, *Fiber-Optic Communication Systems*, John Wiley and Sons, Inc., New York, 2002.
- [10] M. H. Kang, "Development of Broadband Convergence Network and Services in Korea," *Proc. IEEE/OSA Optical Fiber Communication Conference (OFC'08)*, San Diego, CA, Feb. 2008 (Invited Talk).
- [11] G. Keiser, *Optical Fiber Communications*, McGraw-Hill, 2000.
- [12] K.-I. Suzuki, Y. Fukada, D. Nettet, and R. Davey, "Amplified gigabit PON systems [Invited]," *J. Optical Networking*, vol. 6, no. 5, pp. 422-433, May 2007.
- [13] D. P. Shea and J. E. Mitchell, "Long-Reach Optical Access Technologies," *IEEE Network*, vol. 21, no. 5, pp. 5-11, September, 2007.
- [14] T. Nakanishi, K.-I. Suzuki, Y. Fukada, N. Yoshimoto, M. Nakamura, K. Kato, K. Nishimura, Y. Ohtomo and M. Tsubokawa, "High sensitivity APD burst-mode receiver for 10Gbit/s TDM-PON system," *IEICE Electronics Express*, vol. 4, no. 10, pp. 588-592, 2007.
- [15] I. Van de Voorde, C. M. Martin, J. Vandewege and X. Z. Qiu, "The superPON demonstrator: an exploration of possible evolution paths for optical access networks," *IEEE Commun. Mag.*, vol. 38, no. 2, pp. 74-82, Feb. 2000.
- [16] D. J. G. Mestdagh and C. M. Martin, "The Super-PON concept and its technical challenges," *Broadband Communications*, pp. 333-345, Apr. 1996.
- [17] C. Martin, "Realization of a SuperPON Demonstrator," *Proc. NOC*, pp. 118-93, 1997.
- [18] M. O. van Deventer, J. D. Angelopoulos, H. Binsma, A. J. Boot, P. Crahay, E. Jaunart, P. J. Peters, A. J. Phillips, X. Z. Qiu, J. D. Senior, M. Valvo, J. Vandewege, P. Vetter, and I. van de Voorde, "Architecture for 100 km 2048 split bidirectional SuperPONs from ACTS-PLANET," *Proc. SPIE*, vol. 2919, pp. 245-251, Nov. 1996.
- [19] I. Van de Voorde, M. O. van Deventer, P.J.M.Peters, P. Crahay, E. Jaunart, A. J. Phillips, J. M. Senior, X. Z. Qiu, J. Vandewege, J. J. M. Binsma, and P. J. Vetter, "Network topologies for SuperPON," *Proc. IEEE/OSA Optical Fiber Communication Conference (OFC'97)*, 1997.
- [20] M. O. van Deventer, Y. M. van Dam, P. J. M. Peters, F. Vermaerke, and A. J. Phillips, "Evolution Phases to an Ultra-Broadband Access Network: Results from ACTS-PLANET," *IEEE Commun. Mag.*, vol. 35, no. 12, pp. 72-77, Dec. 1997.
- [21] D. B. Payne and R. P. Davey, "The Future of Fiber Access Systems," *BT Tech. Journal*, vol. 20, pp. 104-14, 2002.
- [22] D. P. Shea and J. E. Mitchell, "A 10 Gb/s 1024-Way Split 100-km Long Reach Optical Access Network," *J. Lightwave Technol.*, vol. 25, no. 3, pp. 685-693, Mar. 2007.
- [23] R. P. Davey, P. Healey, I. Hope, P. Watkinson, D. B. Payne, O. Marmur, J. Ruhmann, and Y. Zuiderveld, "DWDM Reach Extension of a GPON to 135 km" *Proc. IEEE/OSA Optical Fiber Communication Conference (OFC'05)*, Mar. 2005.
- [24] G. Talli and P. D. Townsend, "Hybrid DWDM-TDM Long-Reach PON for Next-Generation Optical Access," *J. Lightwave Technol.*, vol. 24, no. 7, pp. 2827-2834, July 2006.
- [25] G. Talli and P. D. Townsend, "Feasibility demonstration of 100 km reach DWDM SuperPON with upstream bitrates of 2.5 Gb/s and 10 Gb/s," *Proc. IEEE/OSA Optical Fiber Communication Conference (OFC'05)*, Mar. 2005.
- [26] G. Talli, C. W. Chow, P. Townsend, R. Davey, T. D. Ridder, X.-Z. Qiu, P. Ossieur, H.-G. Krimmel, D. Smith, I. Lealman, A. Poustie, S. Randel, and H. Rohde, "Integrated Metro and Access Network: PIEMAN," *Proc. 12th European Conf. Networks and Opt. Commun.*, Kista, Sweden, June 2007.
- [27] "Wdm-E-PON (WE-PON)," Working Documents, ETRI, 2007.
- [28] J. A. Lazaro, J. Prat, P. Chanclou, G. M. T. Bellefi, A. Teixeira, I. Tomkos, R. Soila, and V. Koratzinos, "Scalable Extended Reach PON," *Proc. IEEE/OSA Optical Fiber Communication Conference (OFC'08)*, Mar. 2008.
- [29] J. A. Lazaro, I. R. Martinez, V. Polo, C. Arellano, and J. Prat, "Hybrid Dual-fiber-Ring with Single-fiber-Trees Dense Access Network Architecture using RSOA-ONU," *Proc. IEEE/OSA Optical Fiber Communication Conference (OFC'07)*, Mar. 2007.
- [30] F.-T. An, K.-S. Kim, D. Gutierrez, S. Yam, E. Hu, K. Shrikhande, and L. Kazovsky, "SUCCESS: A Next-Generation Hybrid WDM/TDM Optical Access Network Architecture," *J. Lightwave Technol.*, vol. 22, no. 11, pp. 2557-2569, Nov. 2004.
- [31] M. Maier and M. Herzog, "STARGATE: The Next Evolutionary Step toward Unleashing the Potential of WDM EPONs," *IEEE Commun. Mag.*, vol. 45, no. 5, pp. 50-56, May 2007.
- [32] M. Rasztovits-Wiech, A. Stadler, S. Gianordoli, A. Siemens, and K. Kloppe, "10/2.5 Gbps Demonstration in Extra-Large PON Prototype (Invited)," *Proc. ECOC*, 2007.
- [33] I. T. Monroy, F. Yhman, K. Yvind, R. Kjaer, C. Peucheret, A. M. J. Koonen, and P. Jeppesen, "85 km Long Reach PON System Using a Reflective SOA-EA Modulator and Distributed Raman Fiber Amplification," *Proc. Lasers and Electro-Optics Society (LEOS'06)*, 2006.
- [34] R. Kjaer, I. T. Monroy, L. K. Oxenloewe, P. Jeppesen, and B. Palsdottir, "Bi-directional 120 km Long-Reach PON Link Based on Distributed Raman Amplification," *Proc. Photonics in Switching*, 2007.
- [35] H. H. Lee, K. C. Reichmann, P. P. Iannone, X. Zhou, and B. Pálsdóttir, "A hybrid-amplified PON with 75-nm downstream bandwidth, 60 km reach, 1:64 split, and multiple video services," *Proc. IEEE/OSA Optical Fiber Communication Conference (OFC'07)*, 2007.
- [36] P. P. Iannone and K. C. Reichmann, "Hybrid SOA-Raman Amplifiers for Fiber-to-the-Home and Metro Networks," *Proc. IEEE/OSA Optical Fiber Communication Conference (OFC'08)*, Feb. 2008.
- [37] M.-F. Huang, J. Yu; J. Chen, G.-K. Chang; and C. Sien, "A cost-effective WDM-PON Configuration Employing Innovative Bi-directional Amplification," *Proc. IEEE/OSA Optical Fiber Communication Conference (OFC'07)*, Mar. 2007.
- [38] H. Iwamura, G. C. Gupta, M. Kashima, H. Tamai, R. Watanabe, T. Ushikubo, and T. Kamijoh, "42dB Loss Budget Hybrid DWDM-CDM-PON without Optical Amplifier," *Proc. IEEE/OSA Optical Fiber Communication Conference (OFC'07)*, Mar. 2007.
- [39] S.-M. Lee, S.-G. Mun, and C.-H. Lee, "Consolidation of a Metro Network into an Access Network based on Long-reach DWDM-PON," *Proc. IEEE/OSA Optical Fiber Communication Conference (OFC'07)*, Mar. 2007.
- [40] S.-M. Lee; S.-G. Mun, M.-H. Kim, and C.-H. Lee, "Demonstration of a Long-Reach DWDM-PON for Consolidation of Metro and Access Networks," *J. Lightwave Technol.*, vol. 25, no. 1, pp. 271-277, Jan. 2007.
- [41] D. P. Shea and J. E. Mitchell, "Experimental Upstream Demonstration of a Long-Reach Wavelength-Converting PON with DWDM Backhaul," *Proc. IEEE/OSA Optical Fiber Communication Conference (OFC'07)*, Mar. 2007.
- [42] H. Song, A. Banerjee, B. W. Kim, and B. Mukherjee, "Multi-Thread Polling: A Dynamic Bandwidth Distribution Scheme for Long-Reach PON," *IEEE J. Sel. Areas Commun.*, vol. 27, no.2, pp. 134-142, 2009.
- [43] C.-H. Chang, N. M. Alvarez, P. Kourtessis, and J. M. Senior, "Dynamic Bandwidth assignment for Multi-service access in long-reach GPON," *Proc. ECOC*, 2007.
- [44] P. P. Iannone and K. C. Reichmann, "Strategic and Tactical Uses for Extended PON," *Proc. IEEE/OSA Optical Fiber Communication Conference (OFC'08)*, Feb. 2008 (Invited Talk).

**Huan Song** (S'04) received the M.S. degree in Computer Science from the University of California, Davis, in 2006, where he is currently working toward the Ph.D. degree. He is a Research Assistant with the Networks Research Laboratory, University of California, Davis. His research interests include broadband optical access networks, and hybrid wireless-optical broadband access networks.

**Byoung-Whi Kim** has been serving as a Team Leader of WDM-PON Technology Team since 2002 in ETRI (Electronics and Telecommunications Research Institute), Taejeon, Korea. He received the Ph. D. degree from University of Colorado at Boulder in 1993. From 1983 to 1988, he was involved in the development of a digital switching system in ETRI. After he joined ETRI again in 1994, he had worked on III-V compound-semiconductor optical switches based on the strain-induced piezoelectric materials for several years. Since 1998, he has been leading a number of R&D projects in the areas of optical Internet networks based on WDM technology, optical cross connect system, and optical access network. His current R&D interests include optical access network technologies based on DWDM, TDM, and SCM.

**Biswanath Mukherjee** (S'82-M'87-F'07) received the B.Tech. (Hons) degree from Indian Institute of Technology, Kharagpur (India) in 1980 and the Ph.D. degree from University of Washington, Seattle, in June 1987. At Washington, he held a GTE Teaching Fellowship and a General Electric Foundation Fellowship.

In July 1987, he joined the University of California, Davis, where he has been Professor of Computer Science since July 1995 (and currently holds the Child Family Endowed Chair Professorship), and served as Chairman of the Department of Computer Science during September 1997 to June 2000. He is winner of the 2004 Distinguished Graduate Mentoring Award at UC Davis. Two PhD Dissertations (by Dr. Laxman Sahasrabudhe and Dr. Keyao Zhu), which were supervised by Professor Mukherjee, were winners of the 2000 and 2004 UC Davis College of Engineering Distinguished Dissertation Awards. To date, he has graduated 30 PhD students. Currently, he supervises the research of nearly 25 scholars, mainly PhD students and visiting research scientists in his laboratory.

Mukherjee is co-winner of Best Paper Awards presented at the 1991 and the 1994 National Computer Security Conferences, and at the Optical Networks Symposium of the IEEE Globecom 2007 conference. He serves or has served on the editorial boards of the IEEE/ACM Transactions on Networking, IEEE

Network, ACM/Baltzer Wireless Information Networks (WINET), Journal of High-Speed Networks, Photonic Network Communications, Optical Network Magazine, and Optical Switching and Networking. He served as Editor-at-Large for optical networking and communications for the IEEE Communications Society; as the Technical Program Chair of the IEEE INFOCOM '96 conference; and as Chairman of the IEEE Communication Society's Optical Networking Technical Committee (ONTC) during 2003-05.

Mukherjee is author of the textbook "Optical WDM Networks" published by Springer in January 2006. Earlier, he authored the textbook "Optical Communication Networks" published by McGraw-Hill in 1997, a book which received the Association of American Publishers, Inc.'s 1997 Honorable Mention in Computer Science. He was a Member of the Board of Directors of IPLocks, Inc., a Silicon Valley startup company during 2005-07. He has consulted for and served on the Technical Advisory Board (TAB) of a number of startup companies in optical networking. His current TAB appointments include: Teknovus, Intelligent Fiber Optic Systems, and LookAhead Decisions Inc. (LDI). He is a Fellow of the IEEE.

Mukherjee's research interests include lightwave networks, network security, and wireless networks.